

Swing turnstile

Model: RS216



Parameter

- Size: 1200*280*980mm
- Arm material: stainless steel
- Pass width: 600-900mm
- Transit time: 40 people/per minute
- Power input: 110/220v , 50/60hz
- Work humidity: 30%-90%
- Work temperature: -40+70C
- Communication port: rs232/485, dry contact
- Mechanism: 24V brushless motor
- MCBF: 6,000,000 times
- Applications: airport, hotels, office building, school, bank..

Features:

- One way/ two way control
- Anti-tailgating
- Anti-intrusion
- Normal close/ normal open
- 6 pairs of safety sensors
- Sound/light alarm
- Support 3rd party access control
- Passable on power failure
- Durable mechanism
- Pass Number Counter
- Easy operation
- 1 years warranty

Size

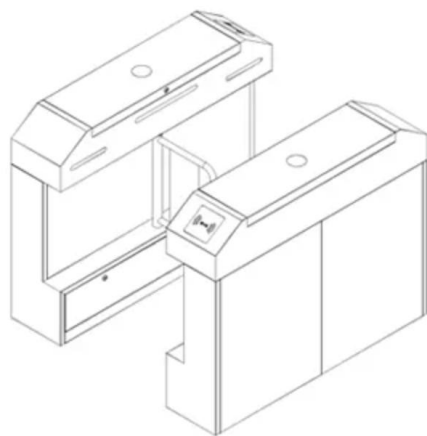
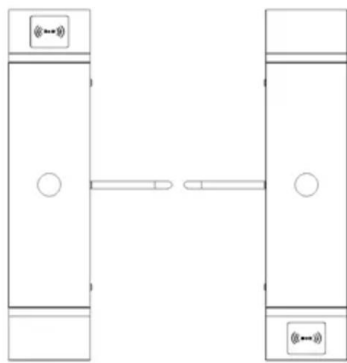
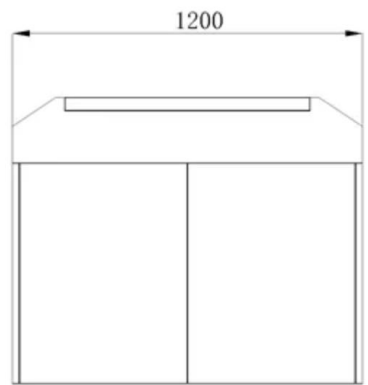
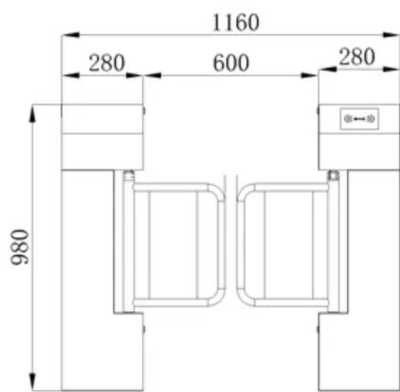

Product Application



Bus and Train Station



School



Hotel



Shopping mall

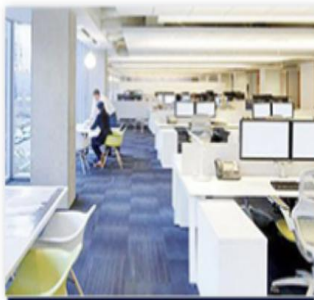

Office building



Hospital